

## Estimates for Evolution of U.S. Rice Supply Response Using Implicit Revenue Functions: Implications to the World Food Supply and Trade\*

Shoichi Ito,<sup>†</sup> E. Wesley F. Peterson,<sup>‡</sup>  
Bharat Mainali,<sup>§</sup> and Mark W. Rosegrant<sup>||</sup>

This research analyzes the evolution of rice supply responsiveness in the U.S. for the past three and a half decades using an implicit revenue function approach. Detailed government program provisions were incorporated into supply function estimates for each of four different periods. Although conventional wisdom maintains that the rice supply response is inelastic, the results of this research indicate that the supply curve has not only shifted outward but flattened, becoming more price-responsive in conjunction with lower market prices, over time. Accordingly, a demand shock may result in less fluctuation in market prices, implying that world market prices are becoming more stable over time and that exporters have to face more competition.

*Keywords:* supply response, implicit revenue function, rice.

### 1. Introduction

Changes in policies and advances in technology may affect the magnitude of supply responsiveness to a change in price. It is well recognized that implementation of new policies such as production controls influences the location of supply curves (Halcrow, Spitze and Allen-Smith [10, pp. 107-147]; and Tarrant [15, pp. 84-94], for example). Tweeten and Quance [16] argue that producers respond differently to rising and falling prices. All aspects of tech-

nological advances such as development of new varieties, and water/pest/disease management have increased yields over time, shifting supply curves outward.

Meanwhile, rigidity in production is often blamed for the volatility of agricultural prices. It is still widely believed that both supply and demand for most agricultural commodities are price inelastic so that small shifts in either of these two schedules will lead to dramatic changes in prices (Hallberg [11, p. 83]). If agricultural production has become more flexible during recent years, the magnitude of the price volatility of agricultural products may be less than that in the past, however. And if this situation emerges in a major exporting country, it suggests that world market prices may be less volatile.

The concept of "elasticity" has been central to empirical analyses of supply and demand. Supply elasticities may not be much help in understanding the evolution of supply responsiveness, however (Appendix A). Given shifts in supply curves which appeared to be taking place in U.S. rice, it is important to investigate the magnitude of supply curve shifts over time and where they are located currently. The

\* This research was funded through a project entitled "Projection and Policy Implications of Medium and Long Term Rice Supply and Demand" under the auspices of IFPRI originally funded by the Ministry of Foreign Affairs, Japan and the project "World Production Potential and Marketing of Japonica Rice, II," under *International Scientific Research* (No. 10041073) of the Ministry of Education, Japan. Authors are grateful to Dr. Eric J. Wailes at the University of Arkansas for his invaluable comments on the earlier drafts.

<sup>†</sup> Tottori University, <sup>‡</sup> the University of Nebraska, <sup>§</sup> independent researcher in Washington, D.C.,

<sup>||</sup> Research Fellow at IFPRI (International Food Research Institute).

slope of a supply curve, in particular, is important. If a supply curve is flatter, in other words more responsive to change in market prices, the impact from a shift in the demand curve on change in market price is smaller (Appendix B). This information has critical implication for the volatility of the world rice market. A simple application of supply curves and elasticities estimated in the past may not be a good indicator for more recent periods. Inclusion of each component of various policy variables over time is indispensable for a more precise analysis of current (and past) supply responsiveness. It is important to investigate the price responsiveness of producers in assessing the evolution of supply of a commodity. This research attempts to analyze changes in supply response over time using U.S. rice policy variables and data during the last three and a half decades. Because the U.S. is the second largest rice exporter next to Thailand, changes in U.S. rice supply response affects not only the U.S. domestic market but also the international rice trade arena. The conceptual framework, statistical analyses, results, and conclusion and implications are presented.

## 2. Approaching Methods

Farm programs considerably interfere with producers' decisions on areas planted. It is important to incorporate the complexity of policy variables as well as market prices into the analysis, in order to estimate impacts of supply response to changes in market prices. Chen [3]; Chen, Penson and Teboh [4]; and Chen and Ito [5] analyzed supply responsiveness of U.S. cotton, wheat, and rice, respectively, using implicit revenue functions (IRF). IRF include all types of policy variables affecting producers' revenue including expected farm prices, expected yields, and variable costs. This generates an expected operating return over variable costs (OROVC) per unit area. It is assumed that the variable OROVC reflects "price-supporting, income-supplementing, and output-restricting features of U.S. farm policies" (Chen and Ito [5, p. 187]) as well as chang-

es in market prices.

### 1) OROVC under the 1981, 1985, and 1990 farm bills

Calculation of OROVC for rice during recent years is very complicated due to the more sophisticated policies implemented in response to low market prices. Farm prices never rose above target prices even during the peak in early 1994 (U.S. Department of Agriculture (USDA) [21]). The acreage reduction program (ARP) was used extensively in the 1980s. Further, with the implementation of the 1985 farm bill, the marketing loan system was introduced (Glaser [8]). Under this system U.S. market prices are no longer insulated from the change in world market prices but are immediately adjusted to the level of world prices. Program participants, on the other hand, are not only subsidized for the difference between the target price and the world price but also are eligible for the premium which occurs when U.S. domestic prices are above the USDA announced world market price. Due to the introduction of the marketing loan system, program participation rates increased from 85% under the 1981 farm bill to 95% under the 1985 and subsequent farm bills. Another important feature under the 1985 farm bill is the fact that the 50/92 option was introduced. This allows program participants to further cut production up to 50% of allowed acreage and still receive their deficiency payments on 92% of their allowed acreage.<sup>1)</sup> The 1990 farm bill introduced the flex system, in which program participants could either divert or grow any type of crop including the program crop (but not fruits and vegetables) on 15% of their allowed acreage but without deficiency payments (Pollack and Lynch [13]). These programs are charted in Fig. 1.<sup>2)</sup>

While OROVCs for the program participants and non-participants have to be calculated for the period starting in 1982, OROVC for 50/92 Option participants also have to be calculated for the period starting 1986 under the more recent farm legislation. Expected per-acre OROVCs are calculated for program participants (OROVCY), 50/92 Option participants (OROVC5), and non-program participants (OROVCN) based on expected farm prices, yields, and various policy variables which were announced before planting season each year. Following Chen and Ito, estimation of

1) The 92% portion was reduced to 85% as of 1994 production.

2) Fig. 1 includes some features of 1996 farm bill although the data statistically analyzed in this research are up to 1994.

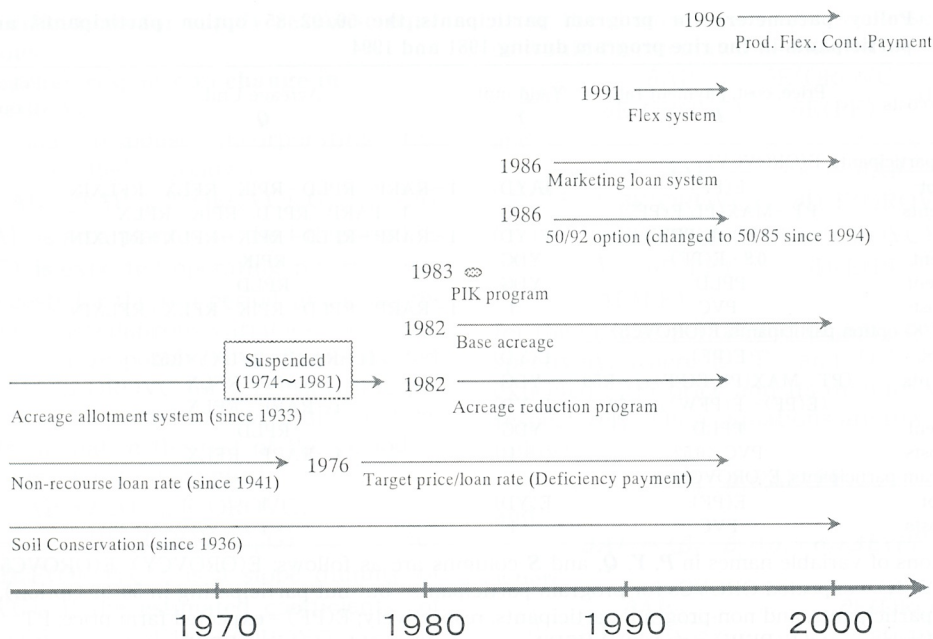

Figure 1. Evolution of U.S. agricultural policies

OROVC is specified as follows:

$$R = P'YQS \quad (1)$$

where,  $R$  is a unit vector of returns over variable costs (OROVC);  $P$ , an  $n \times 1$  vector of market/government prices, implicit revenues and costs per unit;  $Y$ , an  $n \times n$  diagonal matrix of corresponding yields;  $Q$ , an  $n \times n$  diagonal matrix of planted area for government subsidies; and  $S$ , an  $n \times 1$  vector of operating functions for the government program provisions. Yields and variable costs are expressed in values per acre. Table 1 provides each component of OROVC along with  $P$ ,  $Y$ ,  $Q$ , and  $S$  matrixes. Each row in Table 1 is explained in the left column. For example, the first row for  $E$  (OROVCY) represents cash receipts, the second row shows deficiency payments, the third row indicates premium, the fourth row the payment of the PIK program in 1983, the fifth row paid land diversion program payment, and the last row the variable costs. For  $E$  (OROVC5), the first row is cash receipt per acre (0.52 is applied because the participants usually plant more than the 50% level due to established sizes of rice field), the second row expresses deficiency payment, and the third, fourth, and fifth are designated for premium, payment from the paid land diversion pro-

gram, and variable costs, respectively. And last,  $E$ (OROVCN) of non-participants is a multiplication of expected yield and farm price subtracted by variable costs.

These three types of producers account for total rice area planted in the individual rice producing regions. Therefore, total area planted can be decomposed into three individual portions:

$$AY = \alpha AT, A5 = \beta AT, \text{ and } AN = \gamma AT \quad (2)$$

where,  $\alpha + \beta + \gamma = 1, \quad 0 < (\alpha, \beta, \gamma) < 1,$

and  $AY$ ,  $A5$ , and  $AN$  are areas planted by program participants (but not participating in the 50/92 option), 50/92 Option participants, and non-participants, respectively. The Greek letters,  $\alpha$ ,  $\beta$ , and  $\gamma$ , are weights for the individual groups, and  $AT$  is total areas planted. By the same token, OROVC needs to be proportionately weighted according to the contributions to total areas planted to represent an OROVC in each region.

$$E(\text{OROVC}_{82-94}) \equiv \alpha E(\text{OROVCY}_{82-94}) + \beta E(\text{OROVC5}_{82-94}) + \gamma E(\text{OROVCN}_{82-94}) \quad (3)$$

Historically, the proportion planted by program participants and non-participants is 85% and 15% under 1981 farm bill during the 1982 and 1985 production years. Subsequently, the

**Table 1. Policy parameters for program participants, the 50/92/85 option participants, and non-participants in the rice program during 1981 and 1994**

Revenue/costs	Price, cost, payment rate <i>P</i>	Yield unit <i>Y</i>	Acreage Unit <i>Q</i>	Policy option operator <i>S</i>
<i>*Program participants, E(OROVCY)</i>				
Cash receipt	E(PF)	E(YD)	1-RARP-RPLD-RPIK-RFLX+RFLXIN	1
Def. payments	PT-MAX(PL, E(PF))	YDG	1-PARP-RPLD-RPIK-RFLX	C1
Premium	E(PF)-E(PFW)	E(YD)	1-RARP-RPLD-RPIK-RFLX+RFLXIN	C2
PIK payment	0.8×E(PF)	YDG	RPIK	C3
PLD payment	PPLD	YDG	RPLD	C4
Variable costs	PVC	-1	1-RARP-RPLD-RPIK-RFLX+RFLXIN	1
<i>*The 50/92/85 option participants, E(OROV5)</i>				
Cash receipt	E(PF)	E(YD)	(1-RARP-RFLX)×0.52	1
Def. payments	(PT-MAX(PL, E(PF)))×R50	YDG	1-RARP-RFLX	C1
Premium	(E(PF)-E(PFW))×0.52	E(YD)	1-RARP-RFLX	C2
PLD payment	PPLD	YDG	RPLD	C4
Variable costs	PVC×0.52	-1	1-RARP-RFLX	1
<i>*Non-program participants, E(OROV5CN)</i>				
Cash receipt	E(PF)	E(YD)	1	1
Variable costs	PVC	-1	1	1

Definitions of variable names in *P*, *Y*, *Q*, and *S* columns are as follows: E(OROV5CN), E(OROV5), and E(OROV5CN) = expected OROVCs for program participants (but not participating in 50/92 Option), 50/92 Option participants, and non-program-participants, respectively; E(PF) = expected farm price; PT = target price; PL = loan rate; E(PFW) = expected USDA-announced world rice price; PPLD = payment rate for paid land diversion program; PVC = variable costs; E(YD) = expected yield; YDG = government program yield; RARP = rate of acreage reduction program; RPLD = rate of paid land diversion program excluding the PIK program; RPIK = rate of PIK program; RFLX = rate of flex program; RFLXIN = rate of areas flexed-in; R50 = 0.92 for 1986 through 1993 and 0.85 for 1994 production; C1, C2, C3, and C4 are switching variables, where: C1 = 0 if PT < E(PF), otherwise 1; C2 = 0 if E(PF) < E(PFW), otherwise 1; C3 = 1 for 1983 otherwise 0 for the PIK program; and C4 = 1 for years when the paid land diversion program is implemented.

proportions were generally 85% for program participants, 10% for 50/92 Option participants, and 5% for non-participants under the 1985 and 1990 Farm Bills.

## 2) OROVC for 1961 through 1981

Rice has been one of the crops that are protected by the Commodity Credit Corporation (CCC) non-recourse loan program since 1941 (Setia et al. [14]). It was only after the Rice Production Act of 1975 that the both target price and loan rates were applied to rice. During 1961 and 1975, therefore, rice producers basically depended on the loan rate, which was available only for allotment holders, subject to a marketing-quota penalty. Total area planted to rice was consistently less than the total allotted area until 1973 (Childs and Lin [6]).

In the wake of the oil shock and food shortages in the early 1970s, market prices increased and the marketing quota penalty was suspended in 1974 and after. Market prices remained above target prices until the 1981 production year. Rice production before 1974 was controlled by the allotment system for which the

government closely monitored market prices and decided allotted areas for rice each year. Meanwhile, producers expected their revenue to be based on the higher of current market prices or the loan rate, and areas planted were set by the allotment. During 1974 and 1981, when market prices were above the government prices and no marketing quota penalty was imposed, rice producers were free to expand rice acreage while the allotment holders were still entitled to the target prices as a safety net.

Accordingly, the OROVC during 1961 and 1981 should be calculated as follows:

$$E(\text{OROV}_{61-81}) = E(\text{YD}) \times \text{MAX}(\text{PT}, E(\text{PF})) - \text{PVC}, \quad (4)$$

where E (YD), E (PF), and PVC are the same variables as explained above, and PT is loan prices for 1961 and 1975 and target prices for 1976 through 1981.

### 3) Specifications for supply response equations

#### (1) Acreage response to change in E(OROVC)

The acreage response incorporating the OROVC is specified as follows:

$$AP_t = f(AP_{t-1}, E(OROVC)_t | G) \quad (5)$$

where,  $AP_t$  is area planted in the  $t$ -th period,  $E(OROVC)_t$  is expected operating returns over variable costs for the  $t$ -th period, and  $G$  represents other miscellaneous variables. To evaluate a change in responsiveness of area planted to a change in OROVC for a certain time period which is suspected to have a different response from that in the rest of the period, a slope-dummy has to be applied:

$$AP_t = f(AP_{t-1}, E(OROVC)_t, D(E(OROVC))_t | G) \quad (6)$$

where,  $D(E(OROVC))_t$  is a slope dummy of  $E(OROVC)_t$ . If the estimated coefficients of both  $E(OROVC)$  and  $D(E(OROVC))$ , say  $\beta_1$  and  $\beta_2$  with  $\beta_1 > 0$ , are significant, this indicates that there was a change in acreage response to OROVC during the period implied by the slope-dummy. Namely, slopes would be a total of the coefficients,  $\beta_1 + \beta_2$ , for the specific time period relative to  $\beta_1$  for the rest of the observation period. If  $\beta_2$  is positive, acreage responsiveness was stronger for the designated period than the rest, and if  $\beta_2$  is negative with  $0 < |\beta_1 + \beta_2| < |\beta_1|$ , acreage responsiveness was weaker for the designated period.

#### (2) Acreage response to change in prices

Next, it is of particular interest to find acreage responsiveness relative to a change in farm prices over time instead of OROVC; this allows us better understanding of how much the current supply depends on changes in market prices. To do this, it is necessary to estimate the responsiveness of  $E(OROVC)$  to a change in expected farm price,  $E(PF)$ . Because farm policies change over time, the magnitude of the responsiveness of OROVC to PF also changes. Accordingly, it is also important to estimate the difference in response of  $E(OROVC)$  to changes in  $E(PF)$  for a designated period. The following specification will be estimated:

$$E(OROVC) = f(E(PF), D(E(PF))) \quad (7)$$

Assuming both of the estimated coefficients, say  $\delta_1$  for  $E(PF)$  and  $\delta_2$  for  $D(E(PF))$  as a slope dummy, are statistically significant, and

using the chain rule, acreage response to prices would be calculated as follows:

$$\Delta AP_1 = \frac{\partial AP}{\partial E(OROVC)} \cdot \frac{\partial E(OROVC)}{\partial E(PF)} \Delta E(PF), \quad (8)$$

and

$$\Delta AP_2 = \left( \frac{\partial AP}{\partial E(OROVC)} + \frac{\partial AP}{\partial D(E(OROVC))} \right) \cdot \left( \frac{\partial E(OROVC)}{\partial E(PF)} + \frac{\partial E(OROVC)}{\partial D(E(PF))} \right) \Delta E(PF) \quad (9)$$

for the normal period and dummy period, respectively, where  $E(PF)$  and  $D(E(PF))$  are expected farm price and its dummy variable, respectively. These equations are rewritten as follows:

$$\Delta AP_1 = \beta_1 \delta_1 \Delta E(PF), \quad (10)$$

and

$$\Delta AP_2 = (\beta_1 + \beta_2) (\delta_1 + \delta_2) \Delta E(PF) \quad (11)$$

where,

$$\beta_1 = \frac{\partial AP}{\partial E(OROVC)}, \quad \delta_1 = \frac{\partial E(OROVC)}{\partial E(PF)},$$

$$\beta_2 = \frac{\partial AP}{\partial D(E(OROVC))}, \quad \delta_2 = \frac{\partial E(OROVC)}{\partial D(E(PF))},$$

and if  $\beta_2$  and  $\delta_2$  are both positive, it indicates that the slope of the acreage response schedule during the designated period is greater than the rest of the period.

To show an acreage response supply curve in the supply/demand curve diagram, slopes are expressed as inverses of the total coefficients indicated in equations (10) and (11),  $1/(\beta_1 \delta_1)$  and  $1/((\beta_1 + \beta_2) (\delta_1 + \delta_2))$ , respectively. The flatter the slope in the diagram, the more responsiveness of acreage to change in prices.

#### (3) Production response to changes in prices

Increases in yields over time are critical for production and supply. Equations (10) and (11) can be expressed as production response if both sides of each equation are multiplied by expected yield:

$$\Delta Q = \beta_1 \delta_1 \phi_1 \Delta E(PF) \quad (12)$$

$$\Delta Q = (\beta_1 + \beta_2) (\delta_1 + \delta_2) \phi_2 \Delta E(PF) \quad (13)$$

where  $\phi_1$  and  $\phi_2$  are expected yields for the ordinary period and the designated period, respectively. If  $\phi_2 > \phi_1$ , then supply response during the designated period is expected to be even greater than the magnitude expressed by the acreage response.

#### (4) Expected farm prices and yields

Rice planting takes place during April and

May each year. Therefore, rice market prices during the period immediately preceding planting such as in January through April are critical for rice producers in deciding rice acreage for the year. Up to 1995, the government announced its rice program in January, and the producers were supposed to sign up for the program by the end of March whether or not they participate in the program. While the participants basically made their decision by then, the non-participants had flexibility to a certain extent until the end of the planting season. Therefore, it may be more realistic that expected prices be composed based on average of January-through-April monthly farm received prices for rough rice.

Monthly national average prices received by farmers are available from the U.S. Department of Agriculture (Setia et al. [14]). Meanwhile, monthly wholesale milled-rice price data are available for individual regions in the U.S. Comparing these monthly wholesale price data between the Southern states and California, price movements are quite different in the two areas between the 1980s and 1990s, relative to the movements in the 1960s and 1970s. Opposite price movements occurred about twice as frequently during recent years. Therefore, while monthly national farm prices were employed throughout the period of study for Arkansas and 1961 through 1981 for California, monthly milled-rice wholesale price data adjusted to farm prices based on roughrice were used for California during 1982 through 1994.

Despite the fact that yields may be a function of prices, area planted, research (technology development), weather etc. (Anderson and Hazell [1] and Grant, Beach and Lin [9]), functional estimates for yields may end up with larger variance. Accordingly, expected yields in each individual state was estimated as one year lagged 3-year-moving-average.

### 3. Data

The analysis was conducted based on annual data for 34 years from 1961 through 1994. It was attempted to compare the first half and second half of the study period regarding acreage and production responses to prices. Generally, one might intend to run a regression for the whole period with a slope-dummy for the second half of the period. In the U.S. rice situation, however, the policies drastically changed

after 1981, and estimation of one equation for the whole period may not be appropriate. Therefore, two equations were estimated: one for 1961 through 1981 and another for 1982 through 1994. A dummy slope variable was applied for the first equation for the period of 1977 through the end, 1981. The years 1976 and 1977 are located right at the center of the whole study period. The flex program, introduced in 1991 and imposed on every program participant, had a dramatic impact on producers. Although changes in OROVC due to the flex program are incorporated, there is no reason to believe that area planted would respond to a change in OROVC in the same way that it did before the flex was introduced. In fact, the flex system gave the program participants more flexibility in making decisions on their areas planted while their deficiency payments were cut. Therefore, a slope-dummy during 1991 and 1994 was applied in the second equation. As a result, acreage and production response were estimated for four periods; 1961 through 1976 and 1977 through 1981 by the first equation, and 1982 through 1990 and 1991 through 1994 by the second equation.

Arkansas and California were selected for this study. Arkansas is the largest among the six major rice producing states accounting for approximately 40% of total U.S. rice production. California is the only state outside the South producing rice. Rice production in California differs from the Southern production because the type of rice produced is mainly japonica rice, and there are occasional drought problems. Examination of these two major states should provide a good view of changes in U.S. rice supply response as well as those of other crops over time.

The major sources of data are the USDA's *Agricultural Statistics* [24] and *Rice Situation and Outlook Yearbook* [21], Child and Lin [6] (*Rice: Background for 1990 Farm Legislation*), and Setia et al. [14] (*The U.S. Rice Industry*) for supply-side data and policy variables for rice. USDA's *Oil Crops Situation and Outlook Report* [17] was also used for supply-side data for soybeans. Data for costs of production were taken from *Economic Indicators of the Farm Sector: Costs of Production—Major Field Crops & Livestock and Dairy, 1991* [18] and 1992 [19]. The missing cost data before 1975 and after 1992 were created using a trend of the

**Table 2a. Statistical results of acreage response to OROVC for rice in Arkansas and California**

Dependent variables: Rice area planted (1,000 ac)	Arkansas		California	
	1961-1981	1982-1994	1961-1981	1982-1994
	Intercept	217.09 (185.98)	535.51** (108.53)	136.95** (41.85)
Lag dependent	0.935** (0.152)	0.370** (0.081)	0.486** (0.110)	0.499** (0.078)
E(OROVCR)	0.501** (0.108)	1.135** (0.254)	0.105** (0.030)	0.688** (0.104)
Slope dummy				
1977-81	0.424** (0.158)	- (-)	0.198** (0.038)	- (-)
1991-94	- (-)	0.578** (0.152)	- (-)	- (-)
E(OROVCS)	-2.420** (0.820)	- (-)	- (-)	- (-)
Paid div'n./PIK	- (-)	-1,024.44** (138.64)	- (-)	-200.07** <sup>3)</sup> (21.86)
Int. dummy	-188.04 <sup>1)</sup> (108.44)	- (-)	-167.33** <sup>2)</sup> (38.53)	-32.48 <sup>4)</sup> (15.38)
R <sup>2</sup>	0.967	0.947	0.885	0.945
$\bar{R}^2$	0.956	0.921	0.857	0.917
D.h.	1.111	1.737	1.483	1.319
No. of obs.	21	13	21	13

Numbers in parentheses are standard errors. Markers \*\* and \* indicate 1% and 5% significance levels, respectively. <sup>1)</sup> Applied for a period from 1961 through 1974 for marketing quota/penalty period.

<sup>2)</sup> Applied for 1977 for serious drought problem in California. <sup>3)</sup> Applied only for 1983 PIK program.

<sup>4)</sup> Applied for 1986 and 1991 for drought problems in California.

consumer price index.

#### 4. Results

The results of the regression analyses for areas planted in Arkansas and California indicate not only that the implicit revenue variables explain acreage responses well but also that dramatic changes in acreage responses have occurred in U.S. rice production over time (Table 2a). The first equation for area planted in Arkansas during 1961 to 1981 included the lagged dependent variable, operating returns over variable costs for rice (OROVCR), the slope dummy for OROVCR, operating returns over variable costs for a major alternative crop soybeans in the south (OROVCS), and an intercept dummy for 1961 through 1974 account-

ing for a period of low acreage. Estimated coefficients are statistically significant. The slope dummy for 1977 through 1981 is positive, indicating that area planted during this period was almost twice as responsive to OROVC relative to the previous period.

The second equation for Arkansas during 1982 through 1994 included the lagged dependent variable, its slope dummy for 1991 through 1994, and a paid land diversion variable (Table 2a).<sup>3)</sup> The OROVC for an alternative crop did not fit well and was dropped from the equation. This result may be due to the fact that rice acreage was largely controlled by the government programs and reduced to a level far below the level observed in 1981. Accordingly, producers did not have much choice except for diverting land in line with program requirements.

All the estimated coefficients are statistically significant. The significant positive coefficient for the slope dummy during 1991 and 1994 shows that the acreage responsiveness was greater by 50% relative to 1982-90 period,

<sup>3)</sup> Paid land diversion programs (PLD) are designed to reduce acreage compensating producers with divert payments. The payment-in-kind program (PIK) in 1983 is also a type of paid land diversion program. If PLDs are implemented, rice area planted may decrease while the OROVC for individual producers may increase.

**Table 2b. Responses of areas planted to change in OROVC for different time periods in Arkansas and California<sup>1)</sup>**

	1961-1976	1977-81	1982-90	1991-94
Arkansas Slopes	0.501	0.925	1.135	1.713
California Slopes	0.105	0.303	0.688	0.688

<sup>1)</sup> Results are quoted from the figures in Table 2a. Each number indicates a change in areas planted in 1,000 acre due to change in OROVC by one dollar.

**Table 3a. Statistical results of response of OROVC to farm prices for rice in Arkansas and California<sup>1)</sup>**

Dependent variables: E(OROVC)	Arkansas		California	
	1961-1981	1982-1994	1961-1981	1982-1994
E(PF)	45.57** (4.17)	23.26** (5.13)	52.87** (3.85)	27.76** (8.46)
Slope dummy				
1977-81	6.21 (3.27)	— (—)	13.33** (3.02)	— (—)
1991-94	— (—)	6.87 (3.46)	— (—)	11.22* (3.96)
R <sup>2</sup>	0.870	0.676	0.913	0.583
$\bar{R}^2$	0.856	0.612	0.903	0.500
No. of obs.	21	13	21	13

<sup>1)</sup> Numbers in parentheses are standard errors. Markers \*\* and \* indicate 1% and 5% significance levels, respectively.

**Table 3b. Responses of OROVC to farm prices in Arkansas and California<sup>1)</sup>**

	1961-1976	1977-81	1982-90	1991-94
Arkansas Slopes	45.57	51.78	23.26	30.12
California Slopes	52.87	66.20	27.76	38.98

<sup>1)</sup> Calculated from the estimated coefficients reported in Table 3a.

suggesting that the flex had a considerable impact on areas planted in Arkansas. The flex program made producers more responsive to changes in OROVC.

For California, two regressions were estimated in basically the same manner as for Arkansas (Table 2a).<sup>4)</sup> All the estimated coefficients are statistically significant. The results of the first regression for the 1961-81 period indicate that acreage response to changes in OROVC was greater for the 1977-81 period relative to the previous period in California. The responsiveness almost tripled, a much more dramatic change than Arkansas, while

the magnitude of the estimated coefficients for Arkansas were much greater than those for California. The regression results for the 1982-94 period showed no significant change for the 1991-94 period over the previous period. This may show that the flex system did not have much impact on acreage response in California. Because production costs per acre in California are quite high despite greater yields than in Arkansas, flexed acres were generally diverted in California except when market prices rose considerably. Table 2b shows the total slopes adjusted by the slope dummies for individual periods such as 1961-76, 1977-88, 1982-90, and 1991-94 in both states.

Next, responses of OROVC per acre to changes in farm prices are estimated. The results are presented in Table 3a, while Table 3b shows

<sup>4)</sup> There are no major alternative crops to rice in California; therefore, variables of OROVC for alternative crops were omitted.

**Table 4. Evolution of rice acreage response to farm prices in Arkansas and California**

	1961-1976	1977-81	1982-90	1991-94
Arkansas Slopes <sup>1)</sup>	22.83	47.89	26.40	51.61
California Slopes <sup>1)</sup>	5.546	20.05	19.11	26.83

<sup>1)</sup> Each slope indicates a change in acreage in 1,000 acres in response to a change in farm prices by one dollar.

**Table 5. Evolution of rice production response to farm prices in Arkansas and California**

	1961-1976	1977-81	1982-90	1991-94
Arkansas Slopes <sup>1)</sup>	1,012	2,039	1,324	2,767
Inverse <sup>2)</sup>	$9.879 \times 10^{-4}$	$4.904 \times 10^{-4}$	$7.550 \times 10^{-4}$	$3.613 \times 10^{-4}$
Elasticities <sup>3)</sup>	0.769	0.593	0.170	0.219
California Slopes <sup>1)</sup>	291	1,239	1,401	2,255
Inverse <sup>2)</sup>	$3.433 \times 10^{-3}$	$8.073 \times 10^{-4}$	$7.133 \times 10^{-4}$	$4.433 \times 10^{-4}$
Elasticities <sup>3)</sup>	0.274	0.630	0.355	0.404

<sup>1)</sup> Multiplied by average yield for slopes in Table 4. The figures indicate changes in production in 1,000 cwt in response to a change in farm prices by one dollar. <sup>2)</sup> Inverse of the slope in each period in each state.

<sup>3)</sup> Calculated at the means.

**Table 6. Average figures for different periods in Arkansas and California**

	1961-1976	1977-81	1982-90	1991-94
Arkansas				
Area planted, 1000 ac.	536.6	1,166.0	1,145.5	1,350.0
Yields, cwt/ac, roughrice	44.34	42.58	50.17	53.63
Production, mill. cwt, roughrice	23.79	49.65	57.47	72.40
Expected farm prices <sup>1)</sup>	18.08	14.44	7.38	5.72
California				
Area planted, 1000 ac.	365.1	459.4	412.8	428.0
Yields, cwt/ac, roughrice	52.53	61.78	73.37	84.07
Production, mill. cwt, roughrice	19.17	28.38	30.28	35.98
Expected farm prices <sup>1)</sup>	18.08	14.44	7.67	6.45

<sup>1)</sup> Deflated by consumers price index (1985=100).

the total response for different time periods calculated from the regression results. The figures in Table 3b indicate that farm prices were strong factors in producers' revenue per acre during the 1961-81 period. The impacts decreased by almost half during the 1982-94 period in both states. This reflects the fact that the diverted area per acre designated for rice production become larger after 1981 relative to the previous period, indicating that a portion of income sources per acre was replaced by government subsidies. Note, however, that the magnitude within each regression period is larger for the more recent period.

Now, acreage response to farm prices would be the result of multiplication between the individual slopes of acreage response to OROVC

(reported in Table 2b) and the corresponding response of OROVC to farm prices (reported in Table 3b). The results in Table 4 indicate total responses of acreage to a change in farm prices via responses of OROVC as shown in Equations (8) and (9).

It is important to incorporate increases in yields over time into the acreage response, so that it is possible to evaluate production responses to a change in farm prices. Rice yields decreased during the 1977-81 period in Arkansas due to rapid increases in area planted in the state. However, yields increased dramatically afterward and average yield in 1991-94 period was 53.63 cwt per acre, a 20% increase over 1961-76 period (Table 6). Meanwhile, yields in California increased over time, and

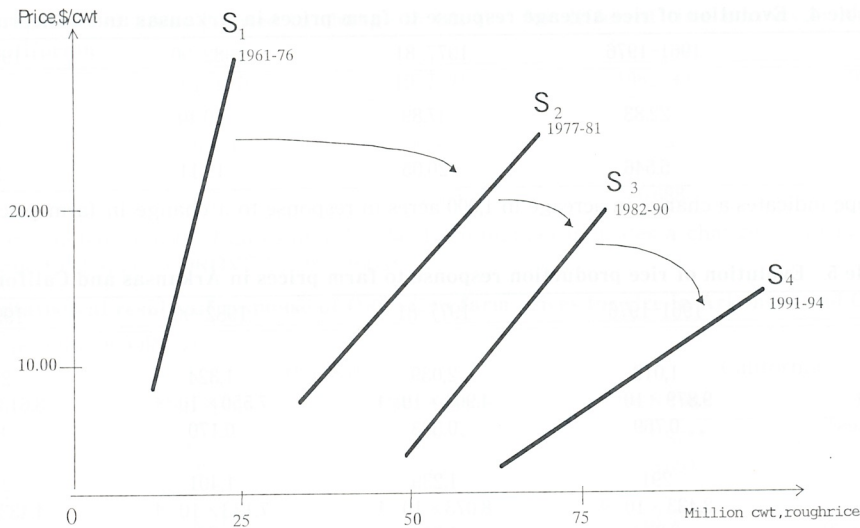

Figure 2. Shift in rice supply curve in Arkansas (1960s-1990s)

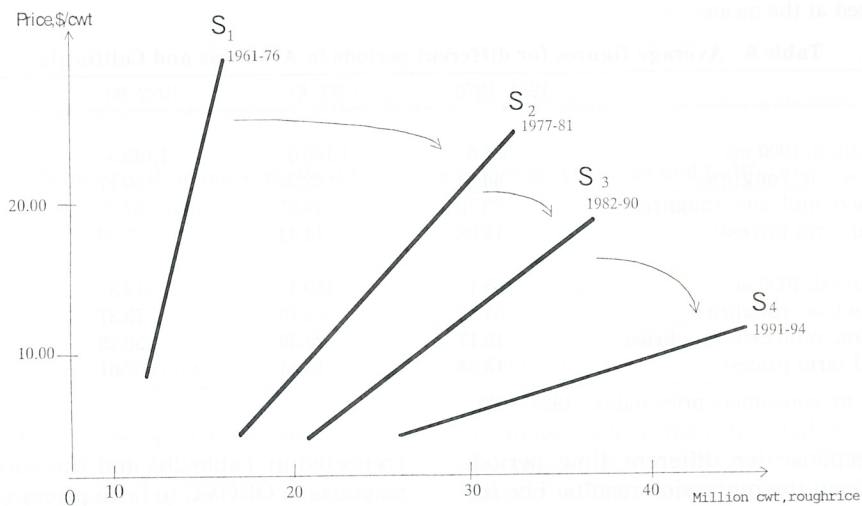

Figure 3. Shift in rice supply curve in California (1960s-1990s)

average yield during 1991-94 period was 84.07 cwt per acre, 60% greater than the 1961-76 period. The numbers in Table 5 are the final estimates of production response of rice to a change in farm prices. A one-dollar increase in farm price led to an increase in rice production of 1 million cwt during the 1961-76 period and 2 million cwt during 1977-81 period in Arkansas. The increase was small (1.3 million cwt) during 1982-90 period due to heavy government control. However, this rose to 2.7 million cwt during the 1991-94 period, almost three times

the effect in the 1961-76 period.

In California, on the other hand, a one-dollar increase in farm price had the effect of raising production by less than a third of a million cwt during the 1961-76 period, but by 1.2 million cwt during the 1977-81 period, an increase of 4 times. Contrary to Arkansas, the increase continued becoming larger during the 1982-90 period, and it reached 2.3 million cwt during the 1991-94 period, eight times as much as the figure in 1961-76 period.

The corresponding inverse figures of the

estimated coefficients become the slopes of the supply curve in the supply/demand diagram. Figs. 2 and 3 show the evolution of supply curves for rice in Arkansas and California, respectively. The flatter supply curves during the more recent years may suggest that production is more sensitive to a change in market prices nowadays, so that the volatility of market prices should be much smaller than before.

Finally, Table 5 also provides supply elasticities for the individual time periods for Arkansas and California. They were calculated based on the estimated coefficients. These elasticities would not provide much information for comparing supply responsiveness over time. Relying solely on elasticities for this type of analysis, one might conclude that supply is becoming more inelastic than before, a view that is the opposite of the current situation.

### 5. Conclusion and Implications

U.S. rice production evolved during the last three and a half decades, while the producers were protected by government programs. Planted areas expanded sharply during the mid-1970s through the early 1980s driven by high market prices. During the rest of the 1980s and 1990s, market prices were depressed and heavy government programs were involved. Meanwhile, yields increased dramatically.

It is important to understand how production response to a change in market prices has evolved. Government programs have also evolved along with changes in market situations and influenced producer behavior. Therefore, it is necessary to include the effects of government programs and other influences in evaluating production responses to change in prices over time. Using an implicit revenue function, which incorporates the complexity of government programs, production responses during the 1961-1994 period were analyzed. According to the results, U.S. rice acreage response to a change in farm prices is much greater in the 1990s than in earlier periods. If increases in yields are incorporated, the magnitude of the production response to a change in prices is even greater, almost three times as large in Arkansas and 8 times as large in California relative to the response during the 1960s through the mid-1970s.

The causes of these changes in responsiveness are multiple. First, increases in yields, which are the composite of newer varieties and better management of irrigation and pest/disease/insects, are phenomenal. Because of higher yields per acre, the magnitude of acreage adjustments required for a given modification of production is smaller. Second, advances in communication technology in conjunction with the application of computer and telecommunications systems transmit market signals to producers more quickly and precisely over time. All of the different information sources such as TV, radio, newspapers and journals have taken advantage of advances in communications technology, and the amount of information made available has increased. Third, it may be true that advances in communications technology also help producers to adopt new production technologies more efficiently. Finally, government policies more closely follow the changes in the market situation. While policies used to be rigid and inflexible, they can now be adjusted to changes in market conditions more rapidly, making decisions on area planted more market-oriented.

Now, the U.S. government introduced a completely different policy in April 1996. In the Federal Agriculture Improvement and Reform Act of 1996 (FAIR), the acreage reduction programs and deficiency payments, which had lasted for decades, were abolished (USDA [20]). Producers are now completely free of any restrictions of growing crops except for fruits and vegetables, while they receive the production flexibility contract payments. This new policy may have made the producers easier to respond to change in market prices than with the previous programs.

The statistical results obtained in this research and the new policy implemented in the U.S. since 1996 imply that (1) rice production nowadays is so sensitive to a change in market prices that the fluctuation of market prices should be much less than before; (2) because the supply response is so sensitive, misinformation on expected market prices, if any, tends to create over-supply more easily than before; (3) production responsiveness has become much greater with the introduction of the FAIR. Finally (4) this overall general trend may be augmented in the long run due to further development of production technology

and information services that facilitate market price discovery.

The U.S. is the second largest rice exporter, next to Thailand, so these findings have some important implications for the rest of the world. First, similar changes may be occurring in Asia which accounts for approximately 90% of total world rice production. Despite the fact that many Asian countries are economically less advanced than the U.S., there is no doubt that communications technology has progressed over time in Asia as well. Further, the green revolution and high yielding varieties have spread to most of the Asian countries, and agricultural products are becoming more commercialized (Braun and Kennedy [2]; David and Otsuka [7]; and Hazell and Ramasamy [12]). Second, for rice-exporting countries, the U.S. will remain a strong competitor and become a more reliable supplier for importing countries than before.

Accordingly, international rice trade may no longer be so inelastic as estimated elasticities suggest, and rice imports may be less risky nowadays. The need for importers to pay extremely high prices may be less likely now and in the future. Wailes *et al.* [25, p. 14] forecast that world rice prices in real term decreases over time through 2010. The huge amount of rice imports at 5.9 million tons (milled bases) by Indonesia in 1998 was conducted quite smoothly in the international market arena (USDA [22]). In fact, the imported amount by a single country was unprecedented, and the world total traded amount in 1998 was also a record high at 25.5 million tons. Further, world rice production sharply increased by as much as 8% to 385 million tons from 1993 through 1997 due to a rise in market prices (USDA [22] and [23]).

The fact that more Asian countries are getting involved with rice trade due to decreases or slow increases in domestic rice consumption and due to more market oriented production systems implies that world rice prices will tend to be stabilized at relatively lower levels than before. On the other hand, some countries may import huge amounts of food due to natural disaster. However, if world food production has become more responsive to changes in market prices in recent years and if technology advances continue as demonstrated in the U.S., world market prices should not fluctuate

as much as they used to and may become even less volatile in the future.

#### References

- [1] Anderson, J. R. and P. B. R. Hazell, ed. *Variability in Grain Yields: Implications for Agricultural Research and Policy in Developing Countries*. Baltimore: The Johns Hopkins University Press, 1989.
- [2] Braun, J. von and E. Kennedy, ed. *Agricultural Commercialization, Economic Development, and Nutrition*. Baltimore: The Johns Hopkins University Press, 1994.
- [3] Chen, D. T. "An Integrated Cotton Model with Interactions between Domestic Program Instruments and International Market Forces." Proceedings of the 1987 Beltwide Cotton Conference, Dallas, TX, January 1987.
- [4] Chen, D. T., J. B. Penson, Jr., and J. F. Teboh. *The Implicit Revenue Function Approach to Farm Program Analysis*. Texas: Dept. of Ag. Econ., Texas A&M University, and Texas Agr. Exp. Sta. Agricultural and Food Policy Center Staff Rep. No. 88-3, April 1988.
- [5] Chen, D. T. and S. Ito. "Modeling Supply Response with Implicit Revenue Functions: A Policy-Switching Procedure for Rice." *American Journal of Agricultural Economics*, Vol. 74, 1992, pp. 186-196.
- [6] Child, N. W. and W. Lin. *Rice: Background for 1990 Farm Legislation*. U.S. Department of Agriculture, Economic Research Service, Commodity Economics Division, 1989.
- [7] David, C. C. and K. Otsuka, ed. *Modern Rice Technology and Income Distribution in Asia*. London: Lynne Rienner Publishers, 1994.
- [8] Glaser, L. K. *Provisions of the Food Security Act of 1985*. U.S. Department of Agriculture, ERS, Agriculture Information Bulletin No. 498, April 1986.
- [9] Grant, W. R., J. Beach, and W. Lin. *Factor Affecting Supply, Demand, and Prices of U.S. Rice*. Washington, D.C.: National Economics Division, Economic Research Service, U.S. Department of Agriculture, 1984.
- [10] Halcrow, H. G., R. G. F. Spitze, and J. E. Allen-Smith. *Food and Agricultural Policy: Economics and Politics*. New York: McGraw-Hill, Inc, 1994.
- [11] Hallberg, M. C. *Policy for American Agriculture: Choices and Consequences*. Ames: Iowa State University Press, 1992.
- [12] Hazell, P. B. R. and C. Ramasamy. *The Green Revolution Reconsidered: The Impact of High-Yielding Rice Varieties in South India*. Delhi: Oxford University Press, 1991.
- [13] Pollack, S. L. and L. Lynch. *Provisions of the Food, Agriculture, Conservation, and Trade Act of*

1990. U.S. Department of Agriculture, Economic Research Service, Agriculture Information Bulletin Number 624, June 1991.
- [14] Setia, P., N. Childs, E. Wailes, and J. Livezey. *The U.S. Rice Industry*. Economic Research Service, Agricultural Economic Report Number 700, September 1994.
- [15] Tarrant, J. R. *Food Policies*. New York: John Wiley & Sons, 1980.
- [16] Tweeten, L. G. and C. L. Quance. Positivistic Measures of Aggregate Supply Elasticities: Some New Approaches. *American Journal of Agricultural Economics* Vol. 51, 1969, pp. 342-352.
- [17] U.S. Department of Agriculture (USDA), Economic Research Service. *Rice Situation and Outlook Report*, OCS-41, July 1994.
- [18] U.S. Department of Agriculture (USDA), Economic Research Service. *Economic Indicators of the Farm Sector: Costs of Production—Major Field Crops & Livestock and Dairy, 1991*, ECIFS 11-3, February 1994.
- [19] U.S. Department of Agriculture (USDA), Economic Research Service. *Economic Indicators of the Farm Sector: Costs of Production—Major Field Crops & Livestock and Dairy, 1992*, ECIFS 12-13, August 1994.
- [20] U.S. Department of Agriculture (USDA). *Provisions of the Federal Agriculture Improvement and Reform Act of 1996*, An Economic Research Service Report, Agriculture Information Bulletin Number 729, 1996.
- [21] U.S. Department of Agriculture (USDA), Economic Research Service. *Rice Situation and Outlook Yearbook*, RCS-1998, September 1998.
- [22] U.S. Department of Agriculture (USDA). *Rice Outlook*, USDA's online service through Mann Library at Cornell University, November 12, 1998.
- [23] U.S. Department of Agriculture (USDA), Economic Research Service. *PS & D View*, monthly issue, November 1998.
- [24] U.S. Department of Agriculture (USDA). *Agricultural Statistics*, several issues.
- [25] Wailes, E. J., G. I. Cramer, E. C. Chavez, and J. M. Hansen. *Arkansas Global Rice Model: International Baseline Projections for 1998-2010*. Arkansas Agricultural Experiment Station, University of Arkansas, Special Report 189, 1998.

(Received January 22, 1999; accepted March 9, 1999)

**Appendix A: Supply Elasticities and Responsiveness**

Imagine two different supply curves,  $S_a$  and  $S_b$ , with different slopes from each other in Fig. A-1 and assume that they are equilibrium at  $p_a$  and  $q_a$  for  $S_a$  and  $p_b$  and  $q_b$  for  $S_b$ . Supply elasticities,  $\eta_a$  and  $\eta_b$ ,

would be calculated for  $S_a$  and  $S_b$  as follows, respectively:

$$\eta_a = \beta_a p_a / q_a, \text{ and } \eta_b = \beta_b p_b / q_b, \quad (A.1)$$

where,  $\beta_a$  and  $\beta_b$  are supply slopes ( $\partial Q / \partial P$ ) for  $S_a$  and  $S_b$ . Assume that:

$$\beta_b = 2\beta_a, p_b = 3/4 p_a, \text{ and } q_b = 3/2 q_a, \quad (A.2)$$

which describe the situation in Fig. A-1. Relationship between the two calculated elasticities would be:

$$\eta_a = \eta_b, \quad (A.3)$$

exactly identical despite the fact that supply with  $S_b$  is twice as responsive to change in prices as  $S_a$ .

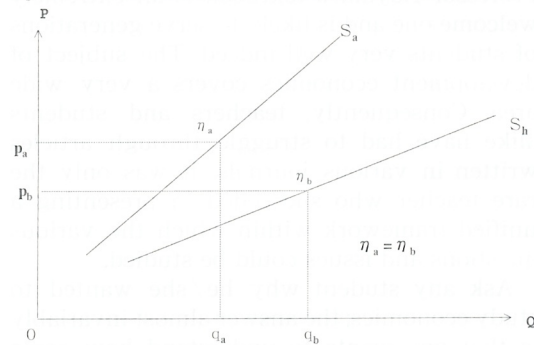
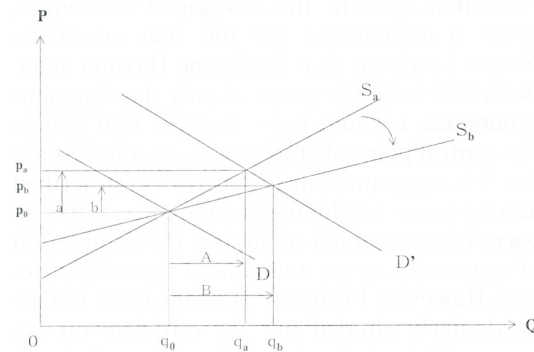

**Fig. A-1. Two supply curves with two identical elasticities**

**Appendix B: Different Impacts Dependent on Slope of Supply Curve**

Fig. B-1 demonstrates the difference in impacts on change in prices depending upon slope of supply curve, when demand curve shifts. The original equilibrium was at  $p_0$  and  $q_0$  for the demand curve  $D$  and supply curves  $S_a$  and  $S_b$  with  $S_b$  being flatter than  $S_a$ .

Assume a case that the demand curve shifts outward from  $D$  to  $D'$ . A new equilibrium with  $S_a$  is at  $p_a$  and  $q_a$ , while the new equilibrium with  $S_b$  is at  $p_b$  and  $q_b$ . Change in prices is much smaller with flatter supply curve,  $S_b$ , than steeper one,  $S_a$ .



**Fig. B-1. Difference in impacts depending upon slope of supply curves**